

**TOP VIEW**

\* Manufacturer reserves the right to modify these specifications in compliance with regulatory agencies and manufacturing expediency.

NOTE: All Three Doors Open in Unison for Inspection & Cleaning Purposes and Allows for Inline or Corner Applications without Conversion Procedures.

**CAUTION:**

Electrical and plumbing connections must be made by a qualified Service Person who will comply with all available federal, state, and local Health, Electrical, Plumbing, and Safety Codes.



**Model HT-25 Specifications**

U.S. REGISTERED PATENTS

RATED CAPACITY (Racks/Hour)	72 NSF Rated
WASH TANK CAPACITY	11 Gal. (41.63 Liters)
WATER TEMPERATURE, WASH	160 F. (71 C)
WATER TEMPERATURE, RINSE	180 F. (82.2 C)
WATER CONSUMPTION	0.85 Gallons/Rack (3.593 Liters/Rack)
WASH MOTOR	3 HP
ELECTRICAL REQUIREMENTS	3PH, 208/240V, 40 AMP, 60 HZ 5-wire connection (neutral, ground, 3 #8 power wires, 50a capacity) SINGLE PH: 208/240V, DUAL CIRCUITS 60/30 AMP, 60HZ CIRCUIT 1: (neutral, ground, 2 #10 ga. wires, 40a capacity) CIRCUIT 2: (2 #8 ga. wires, 75a capacity)
WASH HEATER	8KW
RACK SIZE	19-3/4" X 19-3/4" (50.2 cm x 50.2 cm)
DOOR CLEARANCE	18" (45.72 cm)
WATER INLET (1)	1/2" F.P.T.
DRAIN SIZE	2" F.P.T.
HEIGHT (all doors closed)	74" (187.96 cm)
WIDTH, TABLE TO TABLE (Inline Model)	25" (63.5 cm)
WIDTH w/SCRAP ACCUMULATOR (Overall)	37" (93.9 cm)
DEPTH (Overall)	33.5" (85.0 cm)
SHIPPING WEIGHT	485 POUNDS (219.9 kg)
SHIPPING VOLUME	81.51 cu. feet

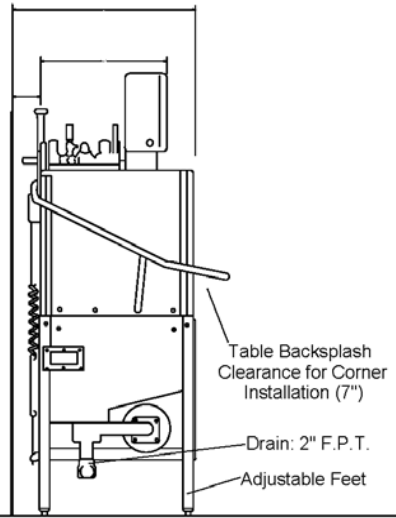

**SIDE VIEW**

NOTE:  
All dimensions listed have a tolerance of  
+ or - 1/8" unless otherwise noted.

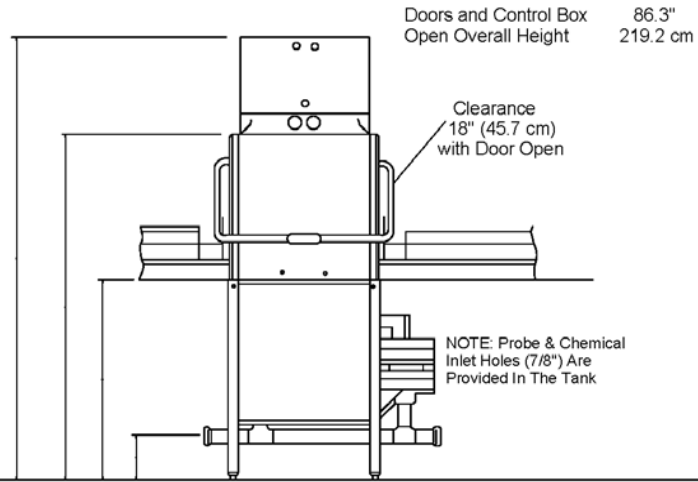

**FRONT VIEW**